

CAM-1629

Plastic Junction Box

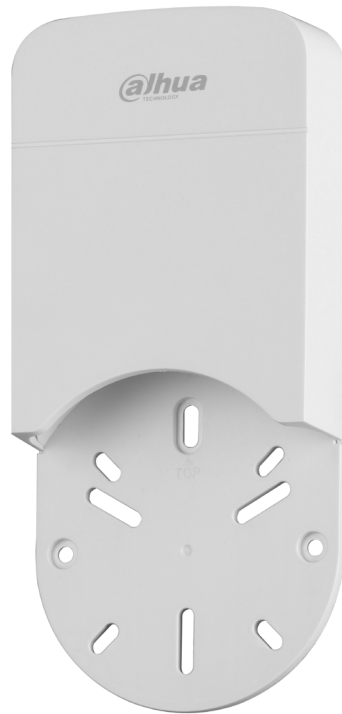

Features

- Material: weatherability and nondiscolouring PP
- Structural water-proof design
- Hidden line design, can place video balun with HDCVI/AHD/TVI/CVBS cameras
- Aesthetic design

Technical Specification

Model	CAM-1629
General	
Material	PP
Dimension (WxHxD)	210.9mmx97.5mmx35mm (8.3"x3.84"x1.38")
Weight	0.1kg (0.22lb)
Color	White
Operating Temperature	-40 °C ~+60 °C (-40 °F ~+140 °F)
Humidity	0~90% RH
Installation	Wall mount
Applicable Model	Please see "Accessory Selector" on www.dahuasecurity.com

Dimension(mm/inch)

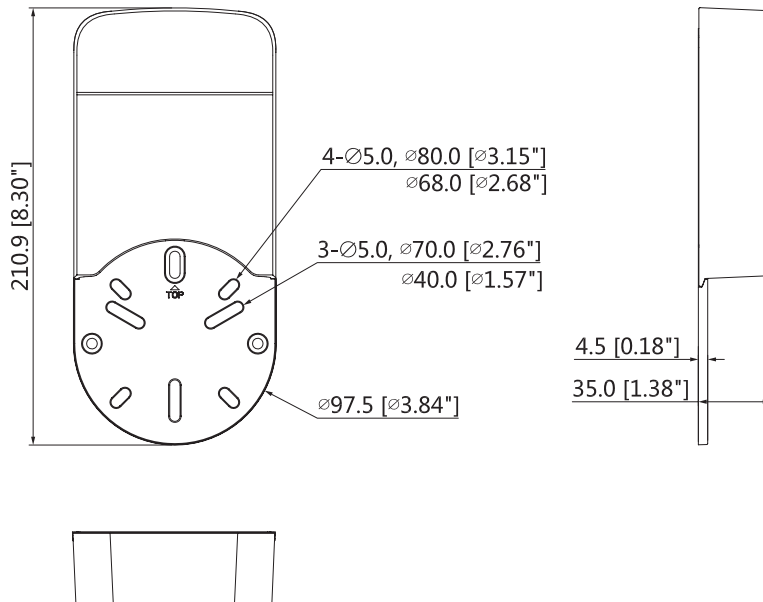

Application

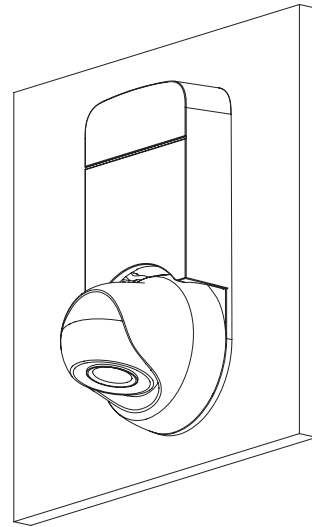
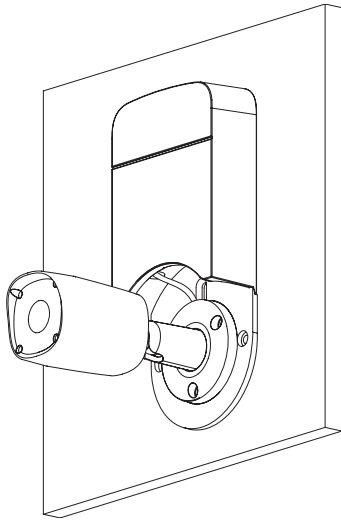

CAM-1629+box camera



CAM-1629+eyeball camera

Package Information

- Plastic junction box CAM-1629 *1
- M4 screw *1
- ST4 screw *1
- Plastic anchor *1
- Mounting sticker *1
- Nylon cable ties with self-locking *3